

# GR Blue PRO

Impeller with grinder system

DESIGN BY

*pininfarina*

All product images are indicative only



## General characteristics

impeller with grinder system	
motor power	0,74 ÷ 1,5 kW
poles	2
discharge	GAS 1½"-DN32 horizontal
free passage	-
max flow rate	5.6 l/s
max head	27 m

## Electromechanical assembly

Electromechanical assembly in EN-GJL-250 cast iron, for submerged operation, fitted with 2 (two) opposing silicon carbide mechanical seals in oil sump, and V-ring in direct contact with the liquid. Ecological dry motor. Pump body in single casting with motor casing.

## Applications

Recommended for unstrained civil wastewaters, including those containing filaments or fibres. This electric pump is intended for both domestic and professional use.

## Construction materials

Case	Cast iron EN-GJL 250
Impeller	Cast iron EN-GJL-250
Nuts and bolts	Stainless steel - Class A2-70
Standard gasket	Rubber - NBR
Cutter material	Chromium steel - X102 CrMo17 KU
Cutting disk material	Chromium steel - X102 CrMo17 KU
Shaft	Stainless steel - AISI 420
Paint type	Ecological bicomponent epoxy (medium thickness 80 µm)
Set of standard mechanical seals	Two silicon carbide mechanical seals (2SiC), V-ring

## Operating limits

Maximum operating temperature	40 °C
PH of treated fluid	6 ÷ 14
Viscosity of treated fluid	1 mm <sup>2</sup> /s
Maximum immersion depth	20 m
Density of treated fluid	1 Kg/dm <sup>3</sup>
Maximum acoustic pressure	70 dB
max starts per hour	30

Models available in IECEx certified version

Ex nA IIC T3  
Ex nA nC IIC T3

# GR BluePRO

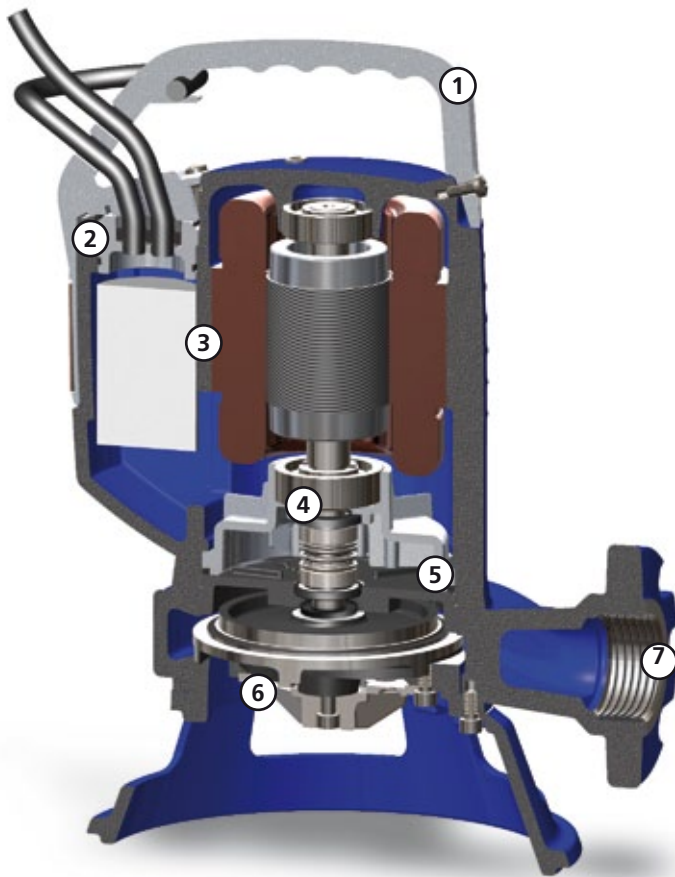

### Lifting handle

Ergonomic technopolymer lifting and carrying handle. Clip floatswitch adjustment.



### Cable gland System

Innovative cable gland system with twin O-rings to ensure maximum tightness.

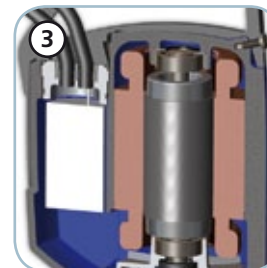

### Motor and electrical equipment

Dry motor with thermal protections. Single-phase models with internal capacitor and control cabinet with circuit breaker capacitor and overload protection. Three-phase models with motor protection relay.



### Mechanical seals

Two silicon carbide mechanical seals (2SiC), and V-ring in direct contact with the liquid.



### Oil sump

Oil sump which guarantees longer mechanical seal lifetime, and is easily accessible thanks to a patented system to simplify maintenance procedures.



### Cutter

Grinder system comprising a revolving cutter and a plate with holes with sharpened edges that fine-chops filaments, preventing fouling of the impeller.

Up to 69.000 cuts per minute



### Discharge and foot

Threaded, flanged discharge for the maximum ease of installation. Cast iron foot.

# GR Blue PRO

Models with horizontal GAS 1½" threaded discharge and DN32 PN6 flange - 2 poles

## Performances

l/s	0	1	2	3	4	5
l/min	0	60	120	180	240	300
m³/h	0	3.6	7.2	10.8	14.4	18.0

① GR BluePRO 100/2/G40H A1CM(T)/50	18.0	16.4	14.4	11.5	6.9
② GR BluePRO 150/2/G40H A1CM(T)/50	21.1	19.6	17.9	15.1	10.4
③ GR BluePRO 200/2/G40H A1CM(T)/50	27.0	25.6	23.6	20.7	16.1

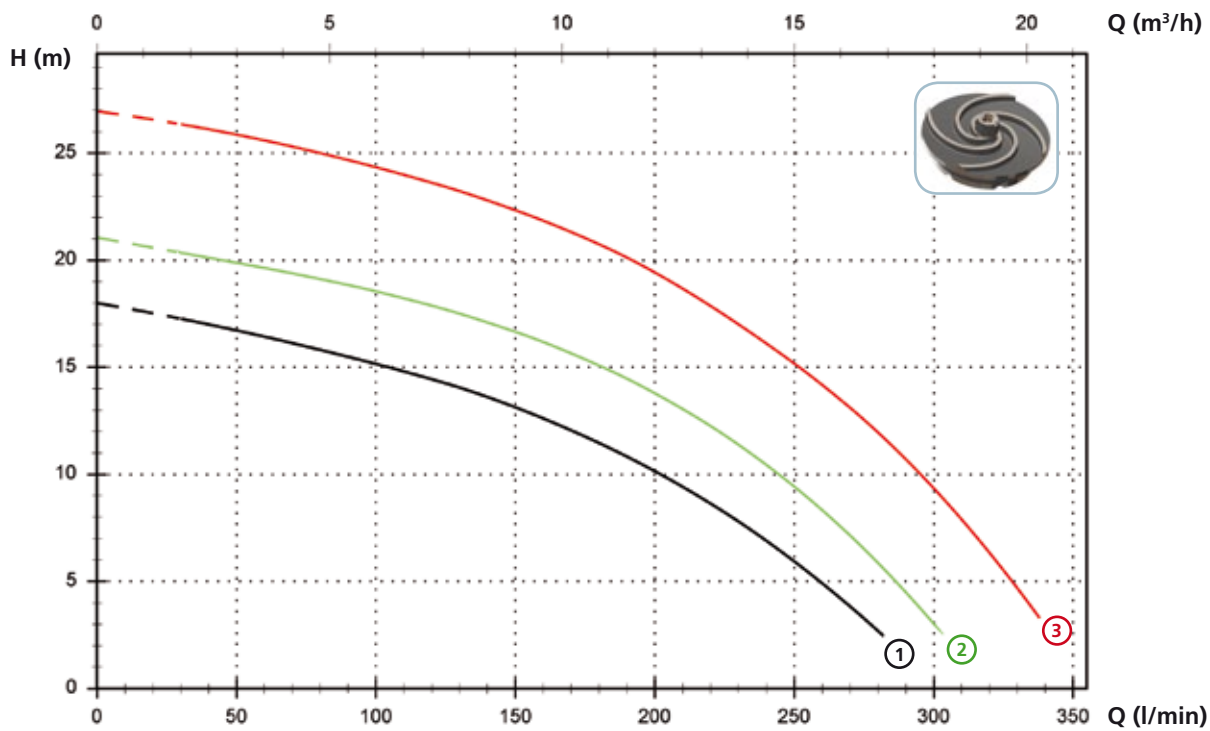

## Technical data

	V	Phases	P1 (kW)	P2 (kW)	A	Rpm	Start	Ø	Free passage
① GR BluePRO 100/2/G40H A1CM/50	230	1	-	0.74	5.5	2900	Dir	G 1½"-DN32 PN6	-
② GR BluePRO 150/2/G40H A1CM/50	230	1	-	1.1	7.5	2900	Dir	G 1½"-DN32 PN6	-
③ GR BluePRO 200/2/G40H A1CM/50	230	1	-	1.5	10	2900	Dir	G 1½"-DN32 PN6	-

	V	Phases	P1 (kW)	P2 (kW)	A	Rpm	Start	Ø	Free passage
① GR BluePRO 100/2/G40H A1CT/50	400	3	-	0.74	2.7	2900	Dir	G 1½"-DN32 PN6	-
② GR BluePRO 150/2/G40H A1CT/50	400	3	-	1.1	3.2	2900	Dir	G 1½"-DN32 PN6	-
③ GR BluePRO 200/2/G40H A1CT/50	400	3	-	1.5	4.3	2900	Dir	G 1½"-DN32 PN6	-

# GR BluePRO

## Versions available

(Key to versions on page 8)

	Electrical variants										Cooling				Mechanical seals					
	N A E	T	T C	T C D	T C D T	T C D G T	T C G	T C S T	T C S G T	T S	T R	T R G	N	CC CCE	FT	C G F T	2SIC	SICM	SICAL	2SICAL
GR BluePRO 100/2/G40H A1CM/50					●	●						●					●			
GR BluePRO 100/2/G40H A1CT/50											●	●	●				●			
GR BluePRO 150/2/G40H A1CM/50					●	●						●					●			
GR BluePRO 150/2/G40H A1CT/50											●	●	●				●			
GR BluePRO 200/2/G40H A1CM/50					●	●						●					●			
GR BluePRO 200/2/G40H A1CT/50											●	●	●				●			

## Overall dimensions and weights

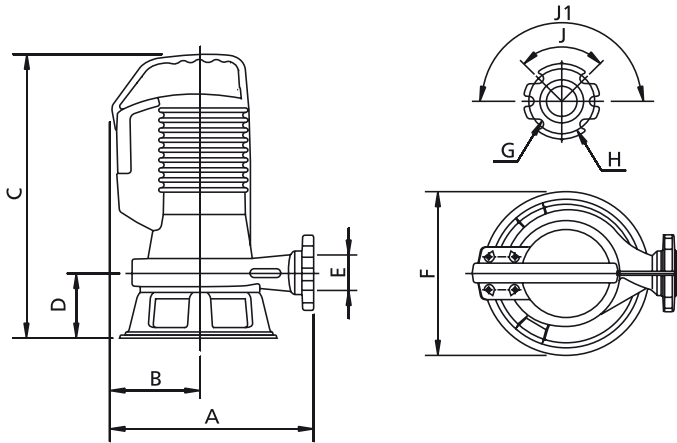

	A	B	C	D	E	F	G	H	J	J1	kg
GR BluePRO 100/2/G40H A1CM(T)/50	270	130	365	95	G 1½"	220	14	90	90°	180°	19
GR BluePRO 150/2/G40H A1CM(T)/50	285	125	410	100	G 1½"	230	14	90	90°	180°	24
GR BluePRO 200/2/G40H A1CM(T)/50	285	125	410	100	G 1½"	230	14	90	90°	180°	25

Dimensions in mm

All weights and dimensions are indicative only

## Packaging dimension

	A	B	C
GR BluePRO 100/2/G40H A1CM(T)/50	300	250	400
GR BluePRO 150/2/G40H A1CM(T)/50	300	250	440
GR BluePRO 200/2/G40H A1CM(T)/50	300	250	440

Dimension in mm

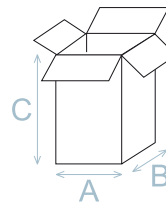

All weights and dimensions are indicative only

## No. pieces per pallet

For GR BluePRO models each pallet (EUR 1000x1200 mm) is able to take 32 pieces.

## Installations available

